

HOOVER™

SilentAir® 4000

Air Purifier

Fanless Electronic Air Purifier

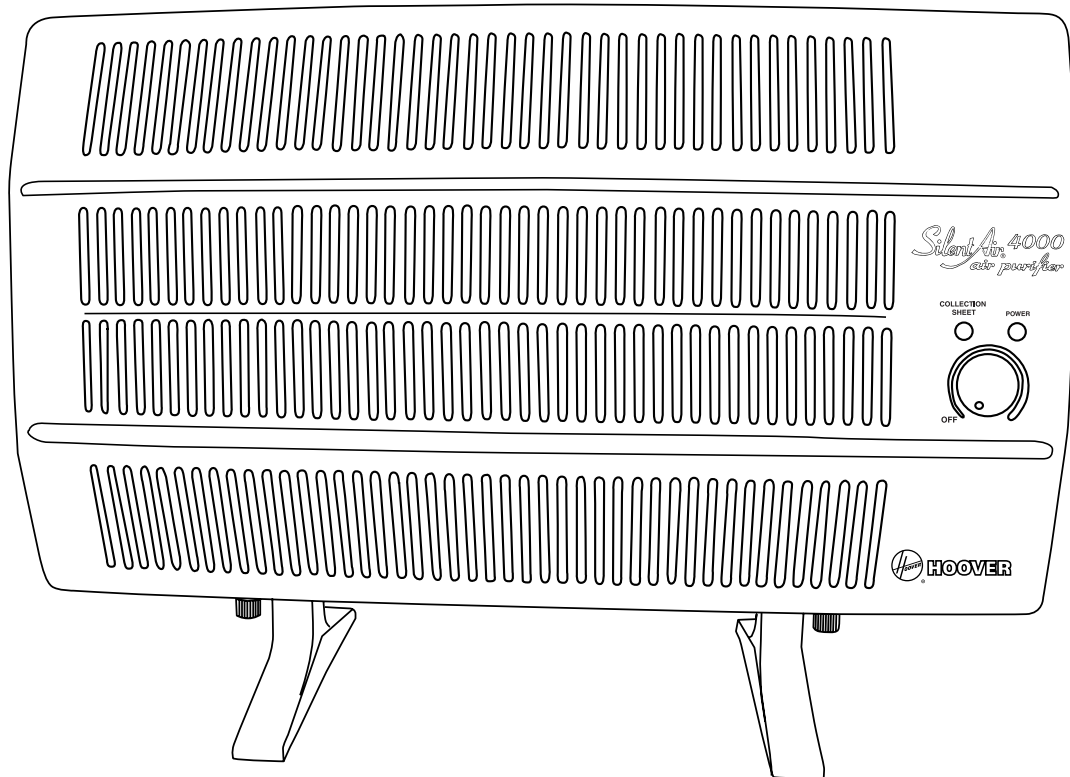

Fill in and retain

The model and serial number are located on the back of the air purifier. For your personal records, please enter the COMPLETE model and serial number in the spaces provided and retain this information.

Your air purifier is model _____

and has serial number _____

It is suggested that you attach your sales receipt to this owner's manual. Verification of date of purchase may be required for warranty service of your SilentAir® product.

Index

Important Safeguards	2
Carton Contents	3
Air Purifier Description	4
Assembly	4
How to Use	5
Maintenance	5
Service	6
If You Have a Problem	7
Warranty	8
Replacement Parts	8

Important Safeguards!

When using an electrical appliance, always follow basic precautions, including the following:

READ ALL INSTRUCTIONS BEFORE USING THIS APPLIANCE

Warning:

 To reduce the risk of electric shock:

- Use indoors only.
- Do not remove the back cover of the air purifier. Doing so is dangerous and will void the warranty of your air purifier.
- Do not operate air purifier with front cover removed.
- Keep the air purifier out of the reach of children or invalids.
- The use of an extension cord is not recommended.
- Turn off all controls before unplugging. Always disconnect cord from electrical outlet before servicing the air purifier.
- Do not unplug by pulling on cord. To unplug, grasp the plug, not the cord.
- Never handle plug or air purifier with wet hands.
- Do not pull or carry by cord. Do not use cord as a handle. Do not close door on cord or pull cord around sharp edges or corners. Keep cord away from heated surfaces.
- Do not use with damaged cord or plug. If the air purifier is not working as it should, has been dropped, damaged, left outdoors, or dropped into water, contact the HOOVER SilentAir Customer Service Center at 1-800-473-8520.
- Do not operate the air purifier near a shower, bathtub or sink.
- Do not operate the air purifier in a bathroom or in a place where steam may be present.
- Do not immerse the air purifier in water or any other liquid.
- Do not operate the air purifier near a stove or heater.
- Keep the air purifier out of direct sunlight.
- Do not operate the air purifier where flammable gases such as oxygen, natural gas or propane may be present.
- Do not put any object into the cover openings.

Save these instructions!



Thank you for purchasing the Hoover™ SilentAir® 4000

The SilentAir® purifier has been designed for simple, problem free operation. If you should happen to need assistance, contact the

HOOVER SilentAir Customer Service Center
1-800-473-8520
www.silentair.com

Carton contents

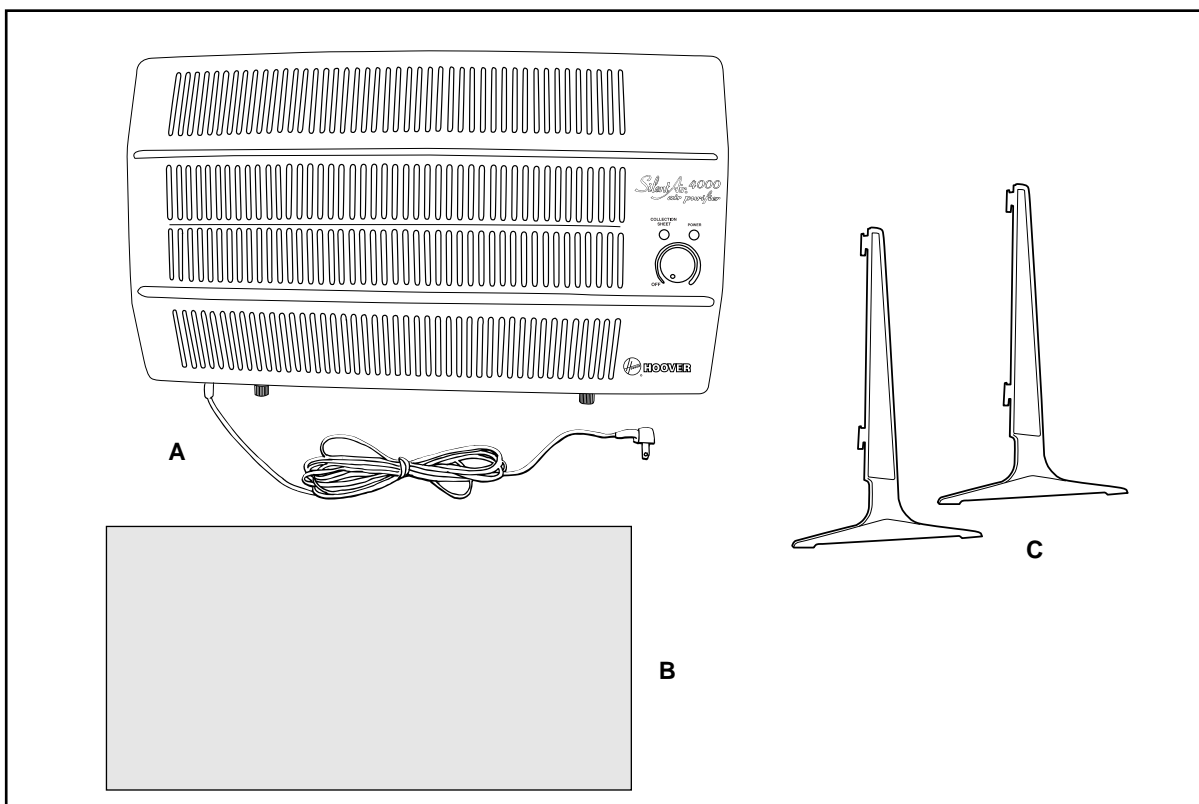

- A. Air purifier
- B. Collection sheet packet
- C. Stands (2)

1. Air Purifier Description

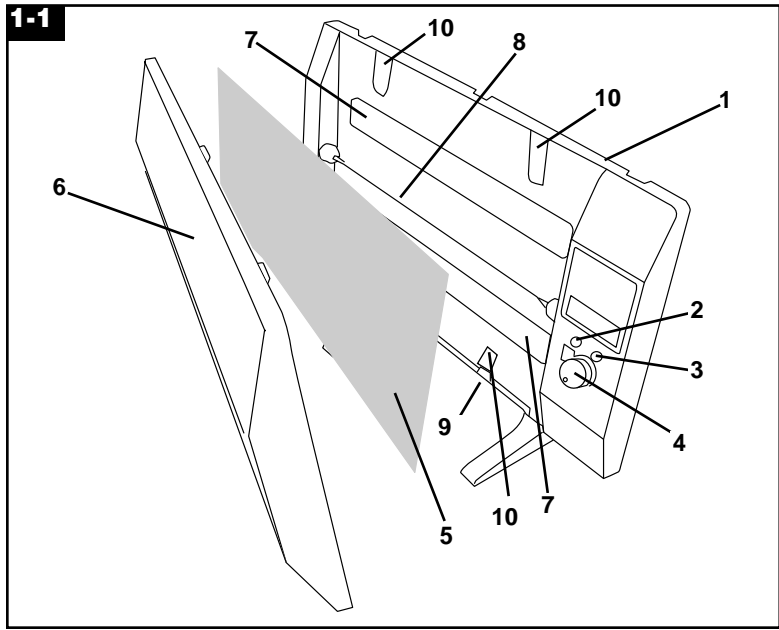

- 1. Main body
- 2. Collection sheet change light
- 3. Power indicator
- 4. Ionization control
- 5. Collection sheet
- 6. Front cover
- 7. Aluminum plates
- 8. Ionization line
- 9. Cover screws (2)
- 10. Holding tabs (4)

Assembly

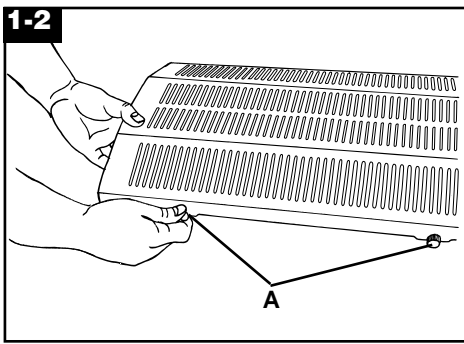

Always disconnect cord from electrical outlet before servicing the air purifier. Loosen cover screws (A) and remove cover. (It is not necessary to remove the screws completely to remove the cover.)

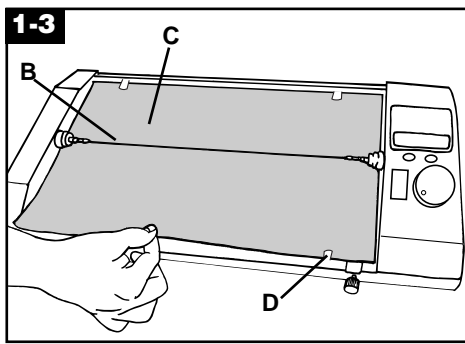

Carefully slide one collection sheet (B) **UNDER** ionization line (C). Place sheet under the four holding tabs (D). (There are 4 tabs, 2 at the top and 2 at the bottom.)

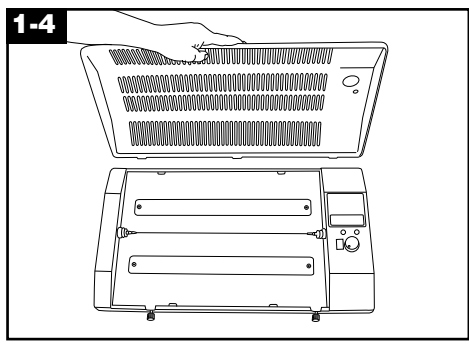

Reposition front cover. Tighten screws.

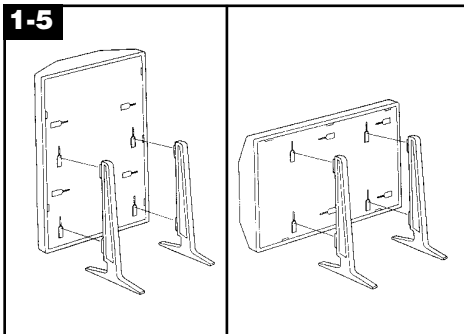

Either a horizontal or vertical position can be chosen.

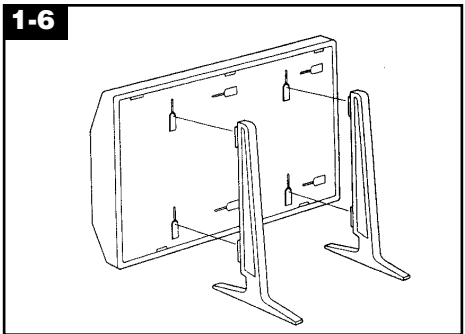

Insert hooks on stand into holes on back of purifier. Slide stand up and snap in place.

2. How to use

Polarized plug

To reduce the risk of electric shock, this appliance has a polarized plug (one blade is wider than the other). This plug will fit in a polarized outlet only one way. If the plug does not fit fully in the outlet, reverse the plug. If it still does not fit, contact a qualified electrician to install the proper outlet. Do not change the plug in any way.

Where to place the air purifier

1. Place your air purifier across the room from an air conditioner or heating vent. If there are no vents in the room, place the air purifier near a return air inlet.
2. Do not place furniture or large objects directly in front of the air purifier.
3. Place the air purifier at least 8 inches (20 cm) away from the wall.
4. In a bedroom, place the air purifier three to four feet (1.2 m) from the bed side.
5. Placing the air purifier near an open window may reduce its efficiency.

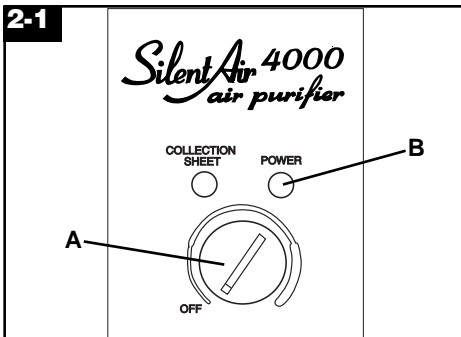

Ionization control

Plug cord into electrical outlet.

Turn ionization control (A) clockwise.

The green power light (B) will turn on.

Room Size	Ionization Control Level
150 sq. ft.	_____
300 sq. ft.	=====
500 sq. ft.	=====

Set the control level according to the size of the room where you plan to use the air purifier.

The SilentAir® purifier is designed to work 24 hours a day, seven days a week, regardless of the control level at which it is set.

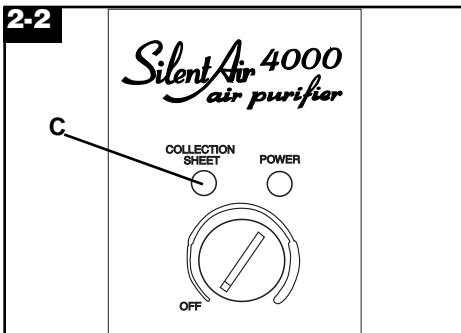

Collection sheet change light

The collection sheet change light (C) reminds you that it is time to change the collection sheet.

Once every 30 days, the light will flash red and the collection sheet should be changed. (See Maintenance section)

3. Maintenance

Collection sheet

When to replace

The collection sheet should be changed about once a month. When the collection sheet change light flashes, it is time to change the sheet. If particle or smoke levels in the room are high, the sheet may need to be changed more frequently.

Please note that the collection sheet change light is automatically reset to a new 30-day period each time the front cover is removed, even if the collection sheet is not replaced. During normal operation, it is generally not necessary to remove the front cover unless replacing the collection sheet. The collection sheet should be changed at least once each month, more often if particle or smoke levels are high.

What to buy

To order collection sheets, call:

1-800-473-8520 or visit

www.silentair.com

Ask for **part no. DCS-4000** (12 sheets per pack)

How to replace

Turn off air purifier and disconnect from electrical outlet.

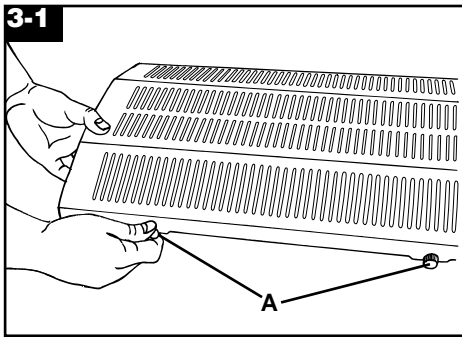

Loosen cover screws (A) and remove cover. (It is not necessary to remove the screws completely to remove the cover.)

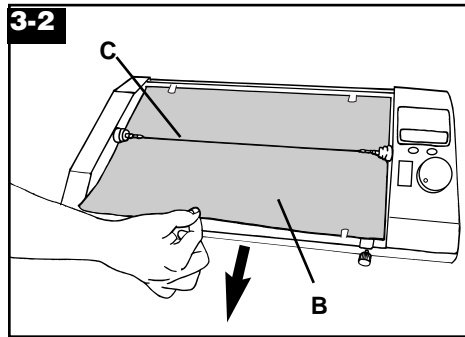

Slide used collection sheet (B) out. Be careful not to snag the ionization line (C).

Discard used sheet.

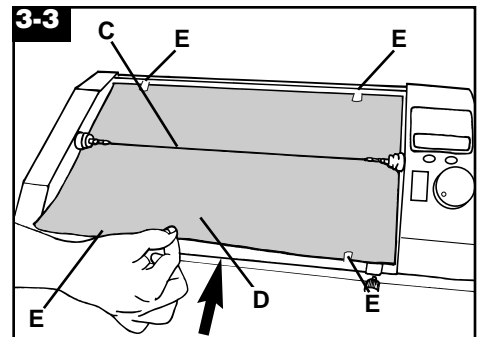

Carefully slide a new collection sheet (D) **UNDER** ionization line (C).

Place sheet under the four holding tabs (E).

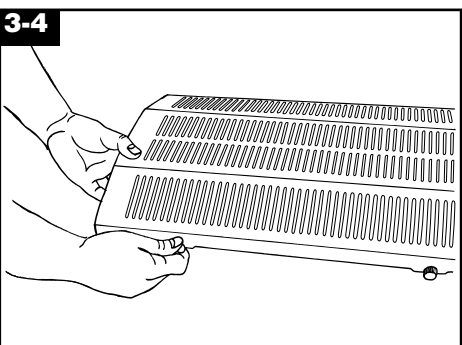

Reposition cover. Tighten screws.

The collection sheet change light will now be reset.

Plug air purifier into electrical outlet and turn ionization control to desired setting.

Cleaning, removing or replacing the ionization line

Note: Use care when handling the ionization line. The line is very delicate and could break easily if mishandled.

The ionization line should be cleaned periodically for the quietest performance possible.

Turn air purifier off and disconnect from electrical outlet.

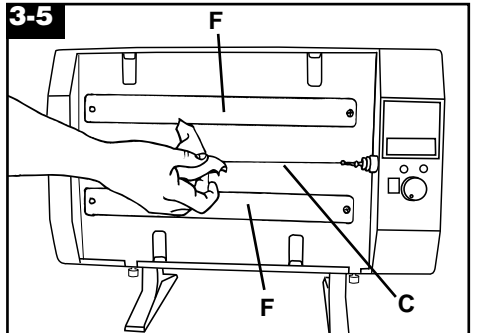

Remove front cover as described for replacing the collection sheet.

Carefully wipe clean the ionization line (C), using a soft, lint-free cloth.

If desired, you may clean the collection plates (F) and the main body with a slightly moistened cloth.

Allow air purifier to dry thoroughly.

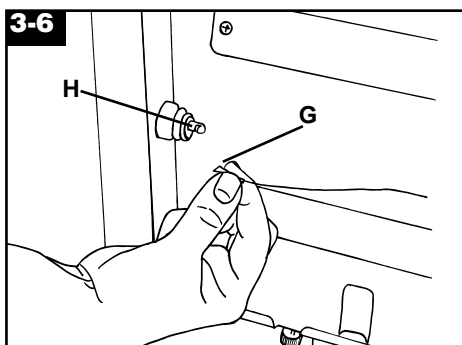

To remove ionization line:

Grasp one end of the line and gently stretch it to release ring (G) from hook (H).

Remove opposite ring from hook.

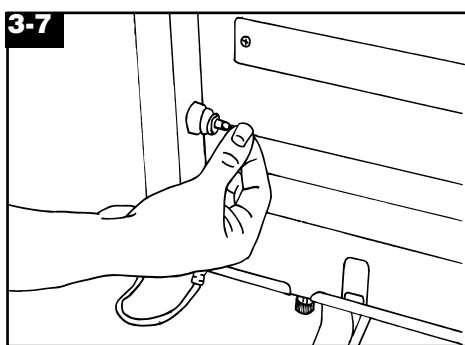

To replace ionization line, slip the ring at one end over the hook. Gently stretch the line, holding the opposite end, to place the other ring over the opposite hook.

Replace front cover.

Service

To obtain approved service, call the HOOVER SilentAir Customer Service Center at **1-800-473-8520**, OR

Visit our website at **www.silentair.com**

5. If you have a problem

If your air purifier is not operating normally, the cause may be easily found by reviewing the list below.

Problem: Power light not on

- **Unit not firmly plugged into electrical outlet**
 - *Plug unit firmly into electrical outlet*
- **No voltage in wall outlet**
 - *Check fuse or breaker*
- **Front cover not secure**
 - *Check cover for proper placement*

Problem: Collection sheet stays clean yet power is on

- **Ionization line is loose**
 - *Disconnect from electrical outlet and check ionization line*
- **Air purifier is dirty**
 - *Disconnect from electrical outlet and clean ionization line, main body and aluminum plates (Figs. 3-5 through 3-7)*

Problem: Air purifier is noisy

- **Air purifier is dirty**
 - *Disconnect from electrical outlet and clean ionization line, main body and aluminum plates (Figs. 3-5 through 3-7)*
- *Replace collection sheet*

Problem: Strong ozone odor

- **Ionization level set too high**
 - *Set ionization control to a lower setting*
- **Collection sheet and/or purifier is dirty**
 - *Disconnect from electrical outlet and clean ionization line, main body and aluminum plates (Figs. 3-5 through 3-7). Replace collection sheet.*

Problem: Light emitted from air purifier

- **Common condition caused by static electricity.**
No action required. Will not harm air purifier.

Problem: Aluminum plates discolored

- **Occurs over time under normal operation**
 - *Discoloration will not harm product performance. Disconnect from electrical outlet and, if desired, replace aluminum plates (part no. SAMP-4000).*

Problem: Static interference on TV, computer or stereo

- **Air purifier too close to other electrical equipment**
 - *Operate air purifier at least four feet (1.2 m) away from other electrical equipment*
- **Air purifier and other electrical equipment share the same electrical outlet**
 - *Plug air purifier and other electrical equipment into separate outlets*

Problem: Static sound coming from air purifier

- **New collection sheet**
 - *Normal condition. Usually disappears in 24 hours.*

One Year Limited Warranty (Standard)
Three Year Limited
Warranty honored if warranty card is returned (Optional)

This product is warranted to the original retail purchaser against defects in materials and workmanship for a period of one year from the date of retail purchase. (Three years if product warranty card is returned.) If this product malfunctions or fails to operate due to a defect covered by this warranty, The Hoover Company or its designee, will, at its option, repair the defective product or replace it with a new product.

Persons covered: This warranty is extended to the original retail purchaser only and is not transferable.

Defects and costs covered: This warranty covers the cost of parts and labor for the repair of defects in materials and workmanship occurring under normal use of the product, and shipping charges for the return of the repaired product to the purchaser.

Defects and costs not covered: This warranty does not cover any defect, malfunction or failure resulting from misuse or abuse of the product, accidents, or the damage resulting from service or repair by anyone except The Hoover Company or its designee.

This warranty does not cover the cost of repair by a non-authorized service center. This warranty does not cover shipping charges for the return of the defective product to the Hoover SilentAir Service Center. **This warranty does not cover consequential damages, incidental damages or incidental expenses, including damage to property. Some states do not permit the limitation or exclusion of consequential or incidental damages, so this limitation may not apply to you.**

Warranty service: If your product requires service covered by this warranty, ship the product postage prepaid to: Hoover SilentAir Customer Service Center, 1660 17th Street, Suite 120, Denver, CO 80202. It is recommended that the product be insured during shipping, as damage resulting from shipping is not covered by this warranty. Include proof of the date of purchase.

Implied Warranties: **Any implied warranties are limited in duration up to three years from the date of retail purchase. Some states do not permit limitations on the duration if implied warranties, so this limitation may not apply to you.**

For replacement parts and collection sheets, call toll free: 1-800-473-8520.

Dielectric Collection Sheets	12 sheets/set	Part #DCS-4000
Dielectric Collecting Plates	2 plates/set	Part #SAMP-4000
Ionization Line	1 line/set	Part #SAIO-4000